

Mascot 55 H

Electro-hydraulic 2-post lift, 5.5 t capacity



Application

- Repair and maintenance

Description:

Posts:

- Symmetrically positioned
- Very stable bent posts
- Without base frame
- Hydraulic pump unit
- Carriage with slide blocks
- Double door-stop
- Pushbutton control unit with alarm signal
- Adjustable end stop and upper protection bar
- Mechanic synchronization
- Electrical safety ratchet system (expensive compressed air not required)

Arms:

- Double telescopic front and rear arms
- Automatic arm locking system
- Low minimum height
- Suitable for passenger cars up to big vans and transporters

Standard colours:

- Arms: RAL 3020 – red
- Posts: RAL 7016 – grey

Optional extras:

- Set of expansion bolts
- Column extension
- A large program of lifting pads
- Adaptor for AUTOPSTENHOJ pads

Special colours available on request!



Scan the QR-Code for detailed product information.

Further Information on www.autopstenhoj.com

AUTOPSTENHOJ GmbH

Sandkampstraße 90
D-48432 Rheine
☎ +49 5971 8602-02
✉ info@autopstenhoj.com

AUTOPSTENHOJ GmbH

Barrit Langgade 188-190
DK-7150 Barrit
☎ +45 76 82 13 30
✉ info@autopstenhoj.com

Technical data	
Lifting capacity	5,500 kg
Lifting height	1,900 mm
Working height	2,000 - 2,047 mm
Lifting / lowering time	approx. 50 sec.
Motor	3.0 kW
Voltage	3x230 / 400 V-50 / 60Hz – 16 A

Arm superstructure	
Lifting pad included in the delivery	100 - 147 mm
Min. height	100 mm
Drive-through width	2,784 mm
Width between posts	3,317 mm
Total width - outer edges base plates	3,832 mm
Total height post	4.015 mm
Arm length front, min. - max.	915 - 1.850 mm
Arm length rear, min. - max.	915 - 1.850 mm

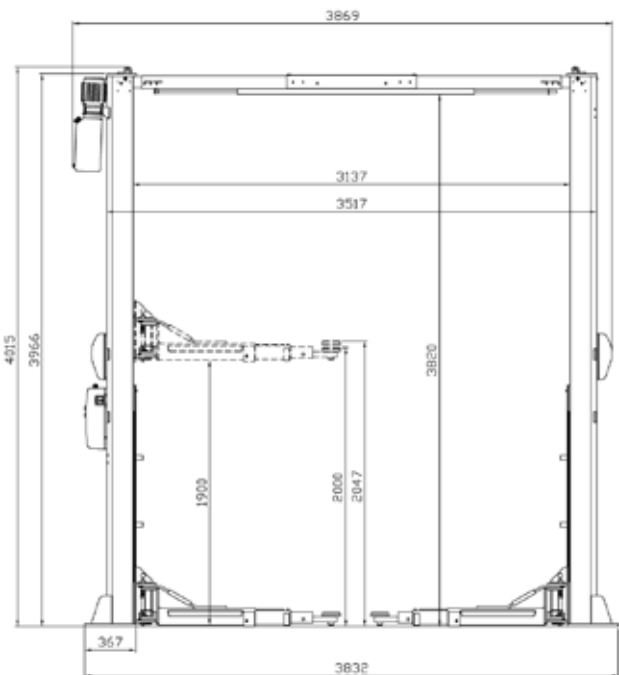
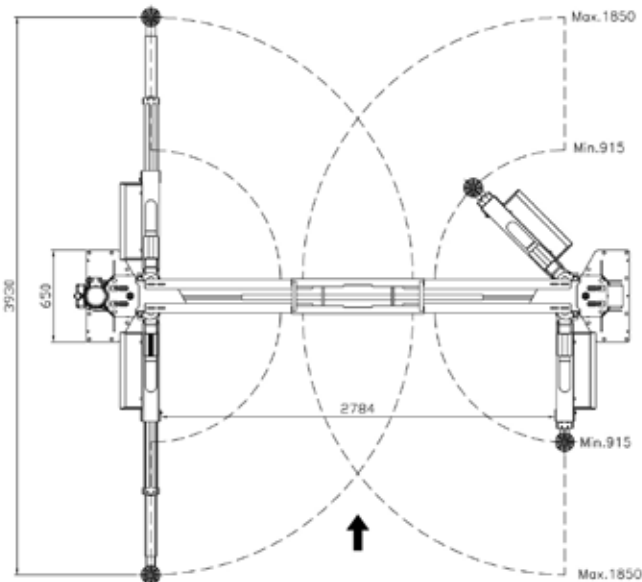
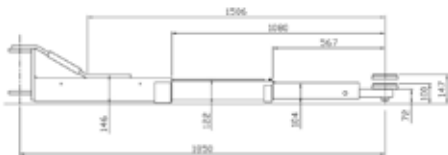

Double telescopic arms



Arm locking system and door stop protection



Pushbutton control with possibility to park in safety ratchets