

stertil **KONI**[®]

ST 1130 & ST 1175

Heavy duty lifting solutions for Big Wheels
and XL Heavy Vehicles 13,000 kg and
17,500 kg per column lifting capacity

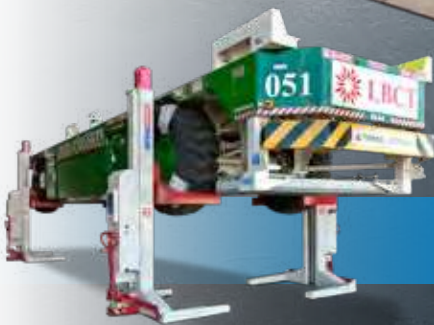

MOBILE COLUMN LIFT

SUPERIOR SOLUTIONS FOR HEAVY DUTY VEHICLE LIFTING

SUPERIOR SOLUTIONS

Stertil-Koni provides customised and technically advanced solutions for heavy-duty lifting requirements for customers throughout the world, including the best possible service from skilled local partners. These superior solutions are conceived, developed and implemented by a team of professional specialists with unique expertise. Thanks to the quality of its people, its entirely in-house production and its international organisation, Stertil-Koni is the world's number one in heavy-duty vehicle lifting.

BIG AND EXTREMELY HEAVY, that's what these two mobile column lifts can cope with in terms of lifting commercial vehicles or equipment.

ST 1130 the BIG tyre lifting solution

The ST 1130 is designed to lift tyres with very large diameters, 2,000 mm - 2,200 mm. The extra long (650 mm) pick-up forks also have the advantage of being detachable. Optional adapters are available allowing for absolute convenience for a wide fleet of vehicles. The ST 1130 has a capacity of 13,000 kg per mobile column lift. Ideal for very heavy and bulky shaped vehicles such as those found at container terminals and construction sites. The ST 1130 is the big-wheel solution for the efficient turnaround of vehicle repair and maintenance.

ST 1175 the highest capacity lifting solution

The ST 1175 is capable of lifting an amazing 70,000 kg in a four mobile column lift configuration. This heavy duty giant is suitable for exceptionally heavy vehicles. Versatility and high return on investment has been engineered into the ST 1175. An optionally available chassis pick-up up adapter can be supplied with the ST 1175 making it possible to lift virtually any vehicle or equipment on the chassis instead of the wheels.

WIRELESS MOBILE COLUMN LIFTS ST 1130 & ST 1175

WITH EBRIGHT SMART CONTROL SYSTEM



UNIQUE
SYNCHRONISATION
SYSTEM

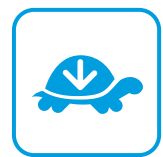

ADJUSTABLE
LOWERING SPEED



MAX 32 LINKED
COLUMNS



The ST 1175 is suitable for a wide range of vehicles and is being utilised in a diversity of industries, such as airport services, tow tugs for aeroplane displacement; logistics and material handling, like containers, trains, tankers and construction. Heavy duty vehicle maintenance has never been made easier.

Full-colour touch screen control

The column lifts are equipped with **ebright Smart Control System**, with a control panel on each individual column. Columns can be operated individually, in pairs or simultaneously as a complete set, with a touch of the 7" high resolution screen. Each column can therefore be used at any given location. Configurations of 32 columns are possible for those extremely heavy jobs.



Cross-beam available for lifting under carriages and chassis



Reliable and long lifetime the Stertil-Koni Hydraulic System

- Long lifetime and excellent R.O.I with minimal repair and maintenance due to reduced friction
- Above industry standards testing
- Manual lowering in case of a power outage, so completely safe and under control
- Maximum protection of the cylinder and seal against damage

Detachable fixed pick-up forks and accessories

ST 1130 and ST 1175 come with detachable fixed pick-up forks. Very versatile for various applications and with optional accessories such as chassis adapters and crossbeams.

Forklengths: ST 1130 - 650 mm, width 1,006 mm

ST 1175 - 450 mm, width 806 mm

Complete with wheel adapters

The ST 1130 and ST 1175 are standardly supplied with two wheel adapters. Suitable for vehicles with wheel diameters starting from 1,000 mm up to 2,200 mm.

Wheel diameters:

- ST 1130 diameters from 1,400 mm up to 2,200 mm, with an average tyre width of 950 mm
- ST 1175 diameters from 1,000 mm up to 1,700 mm, with an average tyre width of 675 mm

For additional wheel diameters special sets of adapters are available for ranges from 950 mm up to 1,400 mm for ST 1130 and 760 mm up to 1,000 mm for ST 1175 respectively.

Synthetic runner wheels with lifetime parts guarantee

The innovative synthetic runner wheels within the column, come with a lifetime parts guarantee.

HEAVY DUTY LIFTING TECHNOLOGY



Ideal lifting solution for big tyres

Easy and damage-free movement around the workshop

Both models are very mobile and very maneuverable with the pallet truck mechanism. The patented overload protection and the integrated retractable wheel system is built into the base frame for 10 x less surface pressure, also preventing damage to the workshop floor.

Safe and smooth column synchronisation

The synchronisation system is activated at a height difference of just 15 mm. This ensures a safe and smooth-running lifting and lowering cycle, even where vehicle or equipment weight load distribution is uneven.

Highest safety requirements

- CE certified (Europe)
- Independent mechanical locking system engages at 45 mm above floor level. Locking pawl engaged by gravity. The locking system is always active, even when the column is turned-off
- Locking profile with increments of just 50 mm
- Synchronisation between the mobile lifting columns starts at a height difference of 15 mm
- Automatic overload protection
- Low voltage control panel
- Each column is equipped with an emergency stop
- Each individual mobile lifting column is tested prior to leaving the factory
- Splash-proof electrical system (IP 65)

The revolutionary **ebright** Smart Control System

The features are:

- High resolution 7" touch screen
- System with user ID key:
 - Individual settings for setting language and units
- - Protection against unauthorised use
- Maintenance notifications
- Visual display of maximum programmable lifting height if set
- Warning and failure information
- Tracking of specific operations and information codes
- Possible to configure an even or uneven number of columns in a set
- Intuitive controls with actual lift data:
 - Indication for Single, All or Pair operation mode
- - Information about how many columns are in the set (up to 32 columns)
- - Actual lifting height displayed
- - Lowering speed can be adjusted on the touch screen
- - Battery status information
- Wireless stable and reliable MESH network with continuous active channel search offering optimal connectivity



SUPERIOR EASE OF USE

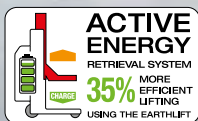

The superior solution for saving energy

No more expensive downtime because of battery charging! The ST 1130 is also available as a EARTH LIFT version. The EARTH LIFT utilises the patented **Active Energy Retrieval System**, which provides you with an ecological, mobile wireless lifting solution, by collecting the gravitational energy that is generated when a raised vehicle descends. The EARTH LIFT has adjustable lifting and lowering speeds. This makes the EARTH LIFT the world's most environmentally friendly wireless mobile column lift.



So versatile that the most awkward shaped vehicles can be safely lifted



Additional reasons why EARTH LIFT is the 'green' standard:

- Lifting column made of recyclable components
- Biodegradable oil in a closed hydraulic system
- Batteries are recyclable
- Electronic components according to environmental norms, RoHS



Technical Specifications ST 1130

Lifting capacity:	13,000 kg per column
Lift technology:	hydraulic lifting system with micro processor-controlled synchronisation
Lifting height:	2,060 mm
Lifting time:	215 seconds
Motor power:	24 V 130A
Weight:	1,500 kg

ST 1130

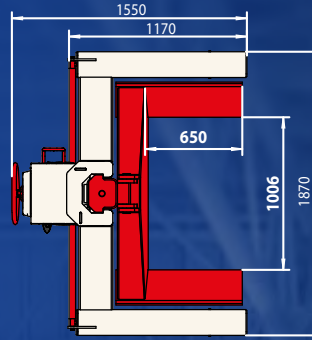

ST 1175

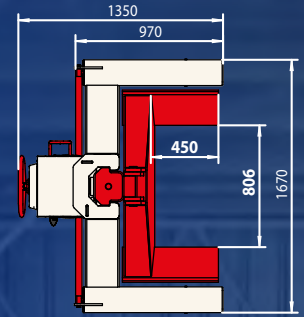

Technical Specifications ST 1175

Lifting capacity:	17,500 kg per column
Lift technology:	hydraulic lifting system with micro processor-controlled synchronisation
Lifting height:	2,060 mm
Lifting time:	215 seconds
Motor power:	24 V 130A
Weight:	1,385 kg

Accessories & Options

Stertil-Koni offers an extensive package of accessories and options tailored to fit your specific needs.

More information

For more information about the ST 1130, ST 1175, or any of Stertil-Koni's lifting solutions, please do not hesitate to contact us. We will be pleased to assist you.

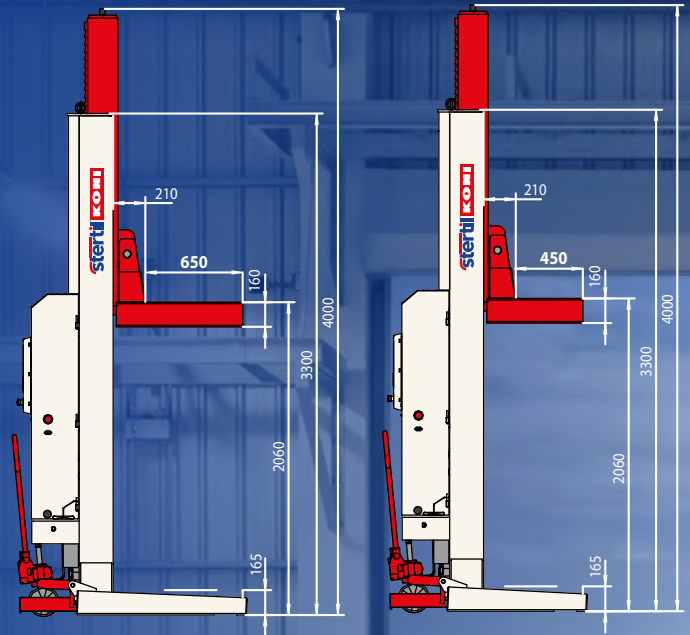

Stertil B.V.
P.O.Box 23
9288 ZG Kootsterille
The Netherlands
Tel. +31 (0)512 334444
www.sterilkoni.com
vehiclelifts@stertil.nl
f Stertil-Koni
@Stertil

a member of the Stertil Group